



10cd Low-intensity Obstruction Light 115V_{AC} - ICAO Type A

CEL-LI-10-115-F - LED Aircraft Warning Light

Key Features

- Based on LED technology
- Extremely reliable - long lifetime
- Suitable for off-shore use
- Very low power consumption
- 115V_{AC} nominal operating voltage
- Stabilised light output
- Lightweight and small - low wind load factor
- Easy to install, several mounting sets available
- Two cable glands, easy to chain without terminal boxes
- No RF-radiations
- Five (5) year warranty
- Patented

Benefits

- Long maintenance intervals
- Low energy cost
- Supply power voltage variations do not affect to light output
- Very low total lifetime costs
- Low wind load

Specifications met

- ICAO International Standards and Recommended Practices:
Aerodromes - Annex 14 Volume 1, 3rd Edition, July 1999,
Chapter 6: Low-intensity, Type A Fixed Obstacle Light

Optical characteristics

- Intensity better than 10cd
- Colour aviation red
- Horizontal radiation pattern 360°
- Vertical radiation pattern 15°
- LED supply current stabilised by constant current generator
- Light output degradation less than 30% after 100,000hrs of operation

Electrical characteristics

- Nominal operating voltage 115V_{AC}
- Power consumption less than 3VA, 1.5W
- Operating voltage range 105 to 125V_{AC}
- Over voltage protection

Mechanical characteristics

- Anodised marine grade aluminium body and end parts
- AISI 316 acid proof steel screws
- Colourless (clear) glass cover
- Terminal box for 1.5-6mm² wires
- Degree of protection IP 65
- Operating temperature range -55°C to +55°C
- Height 210mm, diameter 104mm, weight 1.1kg
- Wind load with CEL-MS-EV60 mounting kit@ 200km/h less than 40N

Options

- Mounting kits
- Light unit with Photocell & flasher: CEL-LI-10-115-PCFL data sheet

Order Code: CEL-LI-10-115-F

Made in EU

Page 1 of 6



CEL-LI-10-115-F LED obstacle light

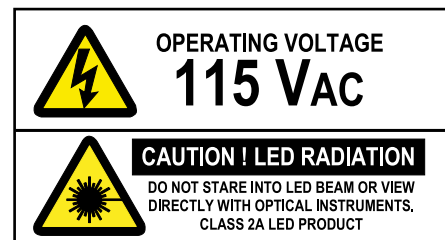

T: +44 (0)20 8540 1034
F: +44 (0)20 8543 3058
E: info@contarnex.com

Contarnex Europe Limited
252 Martin Way,
Morden, Surrey SM4 4AW
United Kingdom



www.contarnex.com

10cd Low-intensity Obstruction Light 115V_{AC} - ICAO Type A

CEL-LI-10-115-F - LED Aircraft Warning Light

ELECTRICAL INSTALLATION INSTRUCTIONS

CEL-LI-10-115-F have two cable glands for easy chaining without external distribution boxes

CEL-LI-10-115-F is an obstacle light utilizing LED technology. The cabling and installation principles are similar to those of conventional obstacle lights.

Connection can be protected with a 6A or 10A fuse or with a circuit breaker (C curve).

Installation specifications

- Cable gland: M25
- Cable diameter: 11 to 17mm
- Wire diameter: max. 6mm²
- Recommended cable: 3x1.5mm² or 3x2.5mm²

Options

- **CGS-20**: Smaller cable glands
Set include 2 pcs M20 gable glands with M25-M20 adapters for 7-13 mm cables

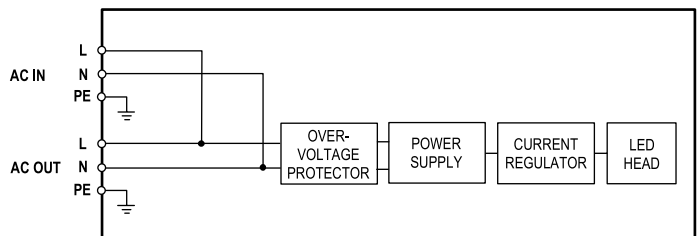
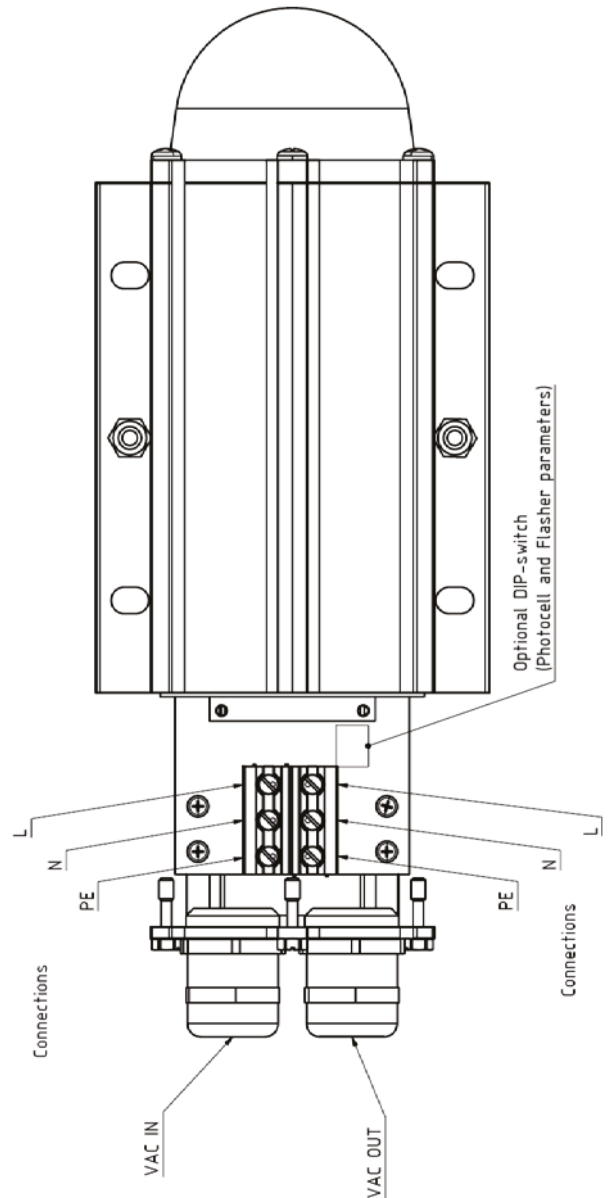
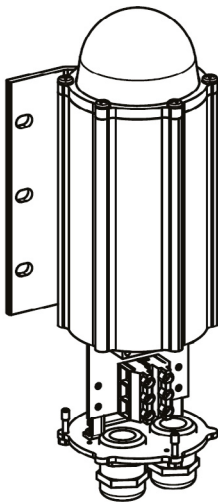

LI-10-115-F block diagram

10cd Low-intensity Obstruction Light 115V_{AC} - ICAO Type A

CEL-LI-10-115-F - LED Aircraft Warning Light

Mechanical dimensions

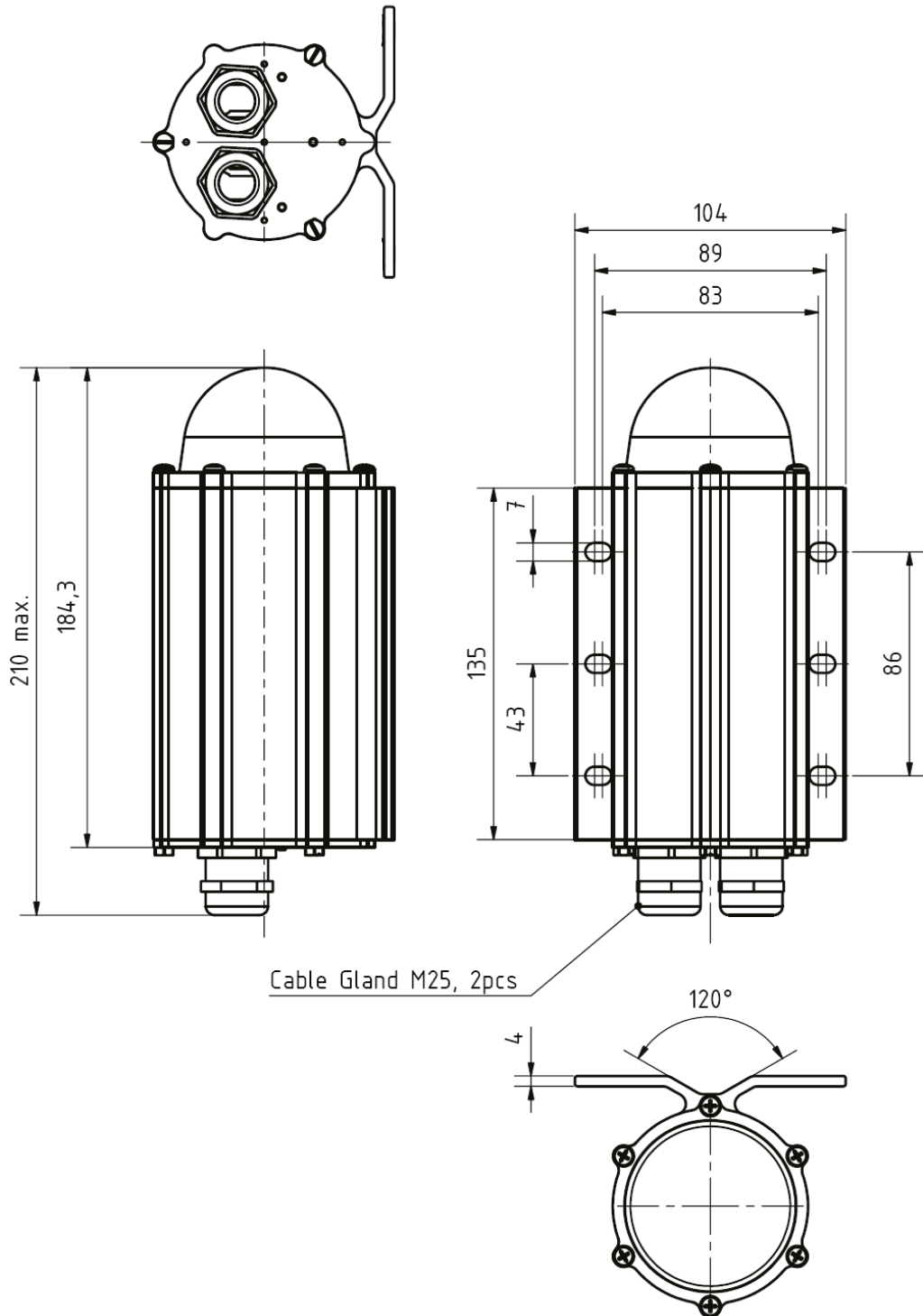

10cd Low-intensity Obstruction Light 115V_{AC} - ICAO Type A

CEL-LI-10-115-F - LED Aircraft Warning Light

There are several types of mounting sets available as option:

CEL-MS-HV80

Mounting set for 33-80mm vertical or horizontal pipe

CS-HV mounting set includes:

- 2 pcs M6 U-bolt
- 8 pcs M6 hex nut
- 4 pcs 6/12 mm washer

All parts AISI 316 acid proof steel

More detailed mechanical data: CEL-MS-HV80 datasheet

Order Code: **CEL-MS-HV80**

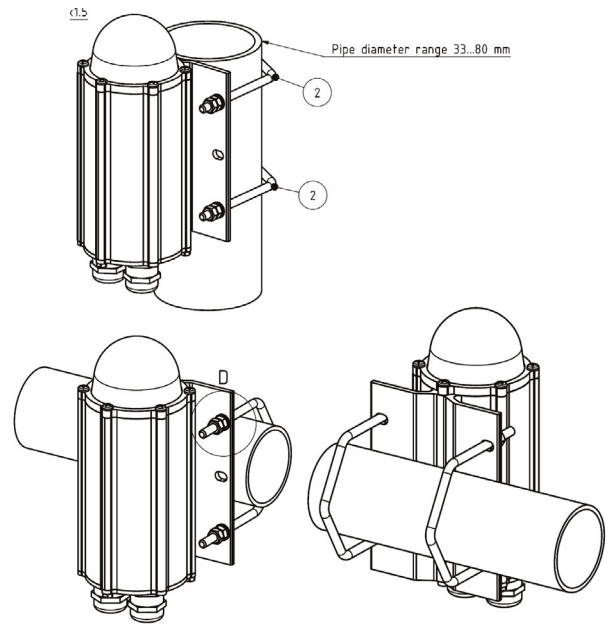

CEL-MS-EV60

Mounting set with extension plate for 30-60mm vertical pipe installation

Mounting set includes:

- 2 pcs M8 U-bolt, 8 pcs M8 hex nut
- 4 pcs M6x30 bolt, 8 pcs M6 hex nut, 4 pcs 6/12 washer
- 1 pcs extension plate

Extension plate marine grade anodised aluminium, other parts AISI 316 acid proof steel

More detailed mechanical data: CEL-MS-EV60 datasheet

Order Code: **CEL-MS-EV60**

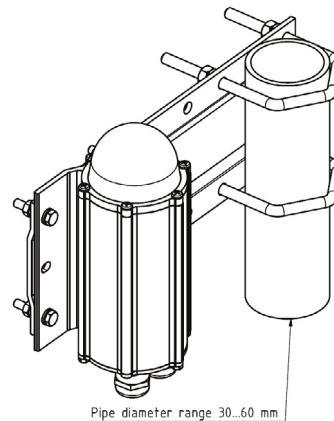

CEL-MS-EV100:

Mounting set with extension plate for 60-100mm vertical pipe installation

Mounting set includes:

- 2 pcs M8 U-bolt, 8 pcs M8 hex nut
- 4 pcs M6x30 bolt, 8 pcs M6 hex nut, 4 pcs 6/12 washer
- 1 pcs extension plate

Extension plate marine grade anodised aluminium, other parts AISI 316 acid proof steel

More detailed mechanical data: CEL-MS-EV100 datasheet

Order Code: **CEL-MS-EV100**

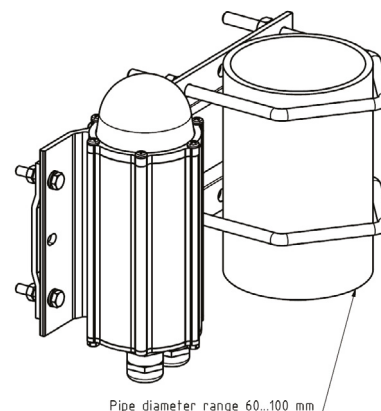

10cd Low-intensity Obstruction Light 115V_{AC} - ICAO Type A

CEL-LI-10-115-F - LED Aircraft Warning Light

CEL-MS-EV150:

Mounting set with extension plate for 100-150mm vertical pipe installation

Mounting set includes:

- 2 pcs M8 U-bolt, 8 pcs M8 hex nut
- 4 pcs M6x30 bolt, 8 pcs M6 hex nut, 4 pcs 6/12 washer
- 1 pcs extension plate

Extension plate hot dipped galvanised steel, other parts AISI 316 acid proof steel

More detailed mechanical data: CEL-MS-EV150 datasheet

Order Code: **CEL-MS-EV150**

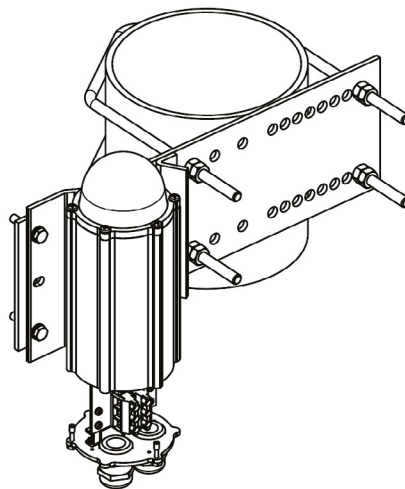

CEL-MS-DEV60:

Double mounting set with extension plate for 30-60mm vertical pipe installation

Mounting set includes:

- 2 pcs M8 U-bolt, 8 pcs M8 hex nut
- 8 pcs M6x30 bolt, 16 pcs M6 hex nut, 8 pcs 6/12 washer
- 1 pcs extension plate

Extension marine grade anodised aluminium, other parts AISI 316 acid proof steel

More detailed mechanical data: CEL-MS-DEV60 datasheet

Order Code: **CEL-MS-DEV60**

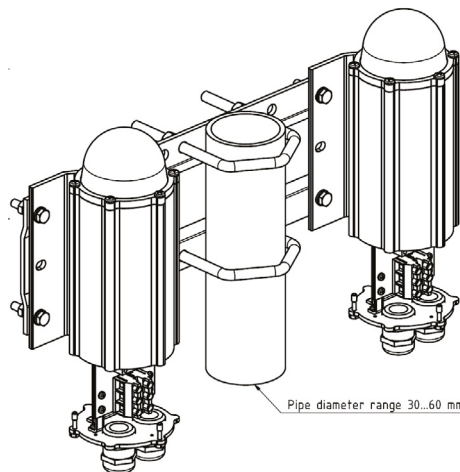

CEL-MS-DEV100:

Double mounting set with extension plate for 60-100mm vertical pipe installation

Mounting set includes:

- 2 pcs M8 U-bolt, 8 pcs M8 hex nut
- 8 pcs M6x30 bolt, 16 pcs M6 hex nut, 8 pcs 6/12 washer
- 1 pcs extension plate

Extension marine grade anodised aluminium, other parts AISI 316 acid proof steel

More detailed mechanical data: CEL-MS-DEV100 data sheet

Order Code: **CEL-MS-DEV100**

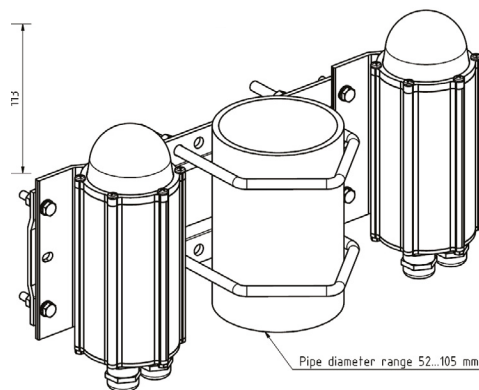

10cd Low-intensity Obstruction Light 115V_{AC} - ICAO Type A

CEL-LI-10-115-F - LED Aircraft Warning Light

CEL-MS-RW

Mounting set for horizontal plate or wall installation

Mounting set includes:

- 4 pcs M6x30 bolt, 8 pcs M6 hex nut, 4 pcs 6/12 washer
- 1 pcs L-shape 2 mm plate

All parts AISI 316 acid proof steel

More detailed mechanical data: CEL-MS-RW datasheet

Order Code: **CEL-MS-RW**

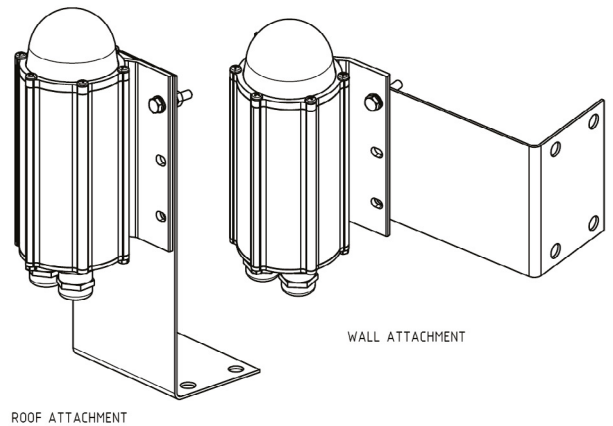

CEL-MS-LVU

Mounting set for L and V -shape profiles

Mounting set includes

- 1 set accessories for light unit fitting to plate
- 1 pcs extension plate with adjusting plate and accessories

Extension plate hot dip galvanised steel, other parts

AISI 316 acid proof steel

More detailed mechanical data: CEL-MS-LVU datasheet

Order Code: **CEL-MS-LVU** (with galvanized extension plate)

CEL-MS-LVA (with AISI 316 extension plate)

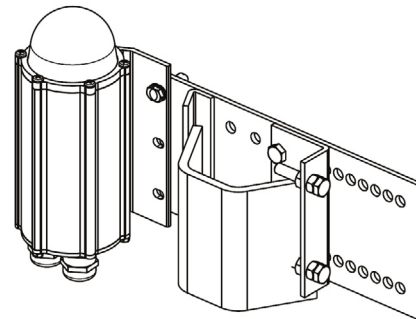

CEL-MS-N1B

Mounting set for 1" NPT at bottom

More detailed mechanical dimensions: CEL-MS-N1B dataheet

Order Code: **CEL-MS-N1B**

